

CrossFlow

High quality product
protection in a *clean
working environment*



 Baker





Professionals in laminar flow and microbiological safety workbenches

Baker designs and produces high-quality microbiological safety workbenches and laminar flow systems for numerous markets and segments.

Our workbenches are mainly used in the pharmaceutical industry, (academic) hospitals, research laboratories, plant breeding and the food industry, but also in various technical applications.

Our goal; let you as a customer benefit from the years of knowledge of Baker, by creating a range of extremely safe, high-quality biological safety workbenches and laminar flow systems - flexibly adaptable to your wishes.

PRODUCT TYPES

You can find us wherever the protection/safety of people, products and the environment against micro-organisms, viruses and dust particles is necessary. All our products are created in close collaboration with you.

Personal Protection

In some laboratories work lab technician must be protected against the substances in the cabinet.

Product Protection

In certain laboratories, the product or research must be performed or processed in a sterile environment.

Personal & Product Protection

There are various activities that are performed in a cabinet where both the person and the product must be protected.

Specials & Projects

If a standard cabinet does not meet your wishes & requirements; we have all disciplines in-house to adjust the cabinet to your needs.



CrossFlow

CrossFlow series is a high quality crossflow cabinet range for handling non-hazardous materials that require a clean working environment. For decades, this high-performance unit has set the standard for working with non-hazardous materials.

The bench area is surrounded in HEPA-filtered clean air, blocking ambient air and particulates to at least maintain ISO Class 5/ GMP Class A conditions, ensuring your work remains contamination-free. Ergonomically designed and operating at low noise levels, the CrossFlow combines comfort with superior protection for your products.

- High quality
- Reliable performance
- Ergonomic design
- Low noise level
- Easy to clean
- User-friendly control panel
- Advanced safety features
- Low energy level



ADAPTABLE FOR MANY APPLICATIONS

The available options and accessories makes this cabinet adaptable for many applications. Together with the flexibility and our expertise, this cabinet is suitable to adapt to your specifications.

- Taps (natural gas, vacuum, O₂, N₂, etc.)
- Electrical sockets
- Cable feed through in worktop
- Stainless steel bar with 8 hooks
- Electrical height adjustable support frame
- Stainless steel worktop
- Stainless steel 304/316 body & support
- Protection grid in front of HEPA filter
- FAT / SAT / IQ / OQ

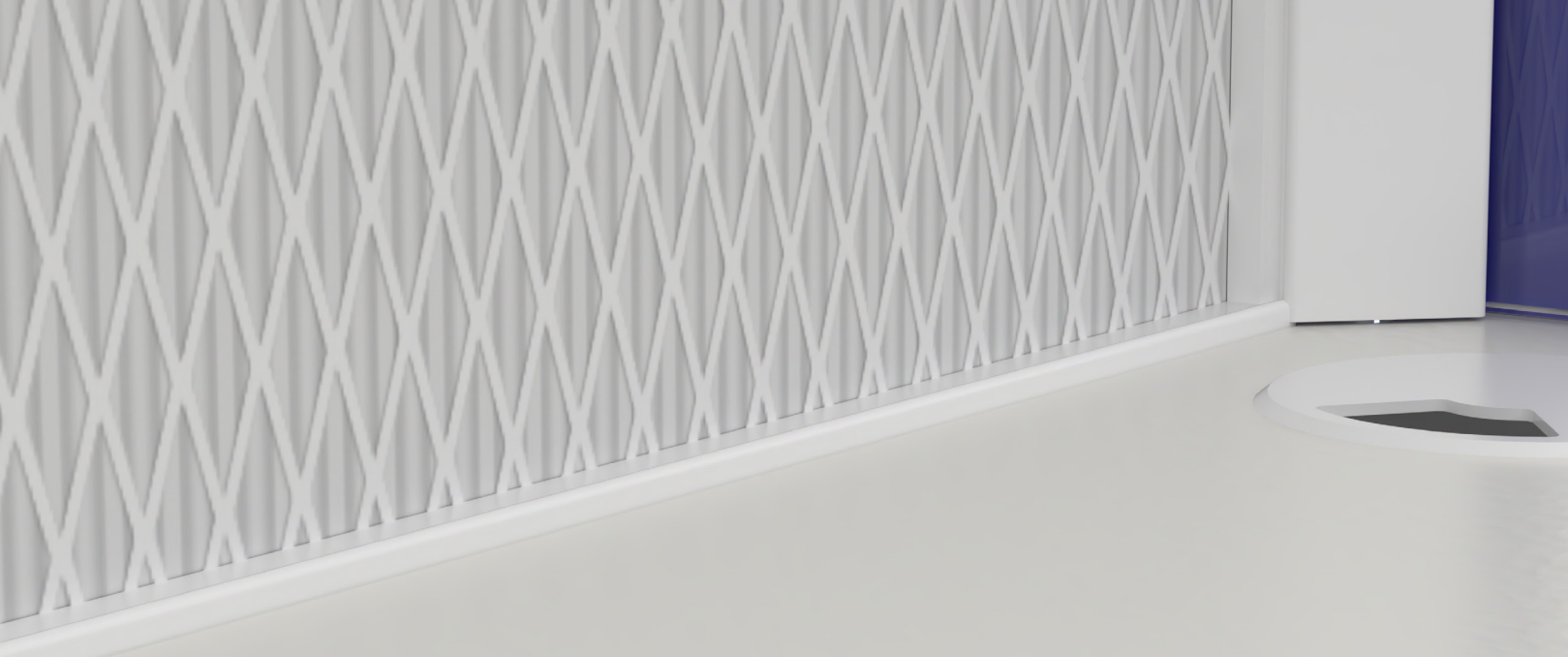

Basic Principles

CrossFlow

APPLICATIONS

In the pharmaceutical, plant breeding, food and beverage industry, biotechnology, pharmacies, and other Industrial applications where sterile work is required. For example, in hospitals, academic laboratories, in tissue culture, cleanrooms and in high tech industries.

AVAILABLE SIZES

CrossFlow series is standard available in (internal) sizes 4, 5 and 6 ft width (120, 150 and 180 cm).

INTERNATIONAL SAFETY STANDARDS

CrossFlow series is designed and manufactured in order to achieve a working area that exceeds the ISO Class 5 (14644-1), Class A (GMP Annex 1), PIC's and equivalent standards.

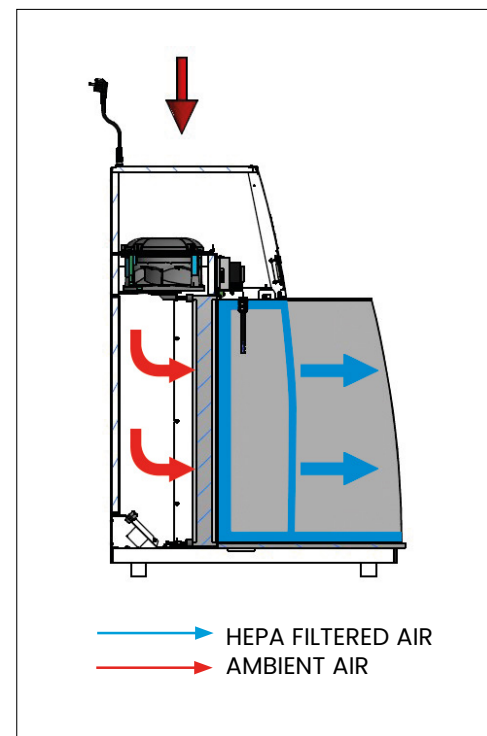

HEPA filtered horizontal laminar airflow (crossflow) creates an ISO Class 5 (14644-1)/GMP Class A (Annex 1) work area and prevents ambient air from entering the work area, ensuring product protection.

FEATURES & BENEFITS

- Complete backwall coverage with a HEPA filter ensures uniform laminar airflow, eliminating dead spots and preventing the reflux of possible contaminated air for a cleaner workspace.
- Thoughtful integrated ergonomic features, including thin HPL worktop, low noise levels, LED lighting, adjustable work heights, and curved saved glass windows make working in CrossFlow comfortable and safe.
- The control panel features alarms and parameters to ensure continuous monitoring of the work process, enhancing safety and efficiency.
- Can be adapted to customer-specific requirements, such as a stainless steel worktop.
- Microprocessors and automatic compensation for filter clogging ensure optimal work conditions and provide advanced product protection.
- Designed with smooth interior for efficient and easy cleaning.
- Including energy-efficient EC fan(s) to save energy
- Upright positioned small barrier at the back of the worktop protects the HEPA filter against spilled liquid.



USER-FRIENDLY CONTROL PANEL FOR INTUITIVELY OPERATING



- Green light indicates safe work mode
- Red light indicates alarm (visual and audible) for Airflow (high/low)
- Switch for work mode (on/off)*
- Switch for stand-by mode (on/off)
- Switch for UV light (on/off)**
- Switch for LED light (on/off)
- Switch for power socket (on/off)**
- English, Spanish, French, German and Dutch language
- Real-time clock
- Total running hours for fan and lights
- Pin code to prevent unauthorised usage
- Volt free contact for forwarding alarms to building management systems

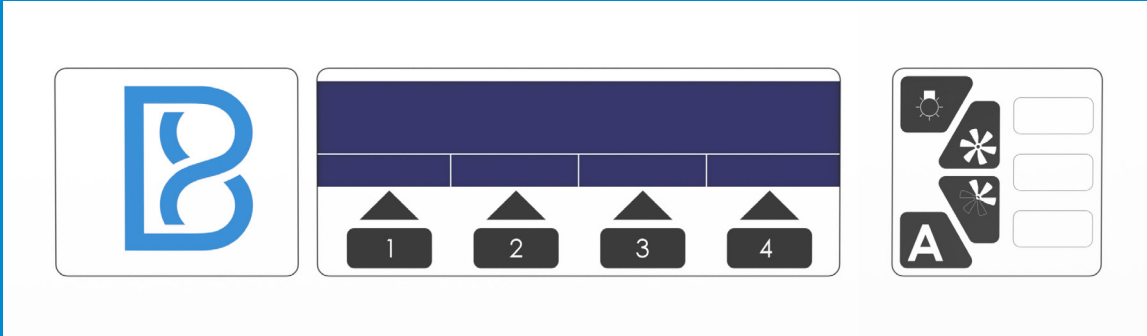

*Also controllable by programmable clock (on) or timer
 **Also controllable by programmable clock (on/off) or timer

Technical Specifications – CrossFlow

Model Number	CLF 475	CLF 575	CLF 675
Product dimensions and weight			
Exterior dimensions (W x D x H)	1270 x 893 x 1153	1575 x 893 x 1153	1880 x 893 x 1153
Interior dimensions (W x D x H)	1249 x 570 x 736	1554 x 570 x 736	1859 x 570 x 736
Weight (kg)	110	150	190
Performances			
Horizontal velocity (m/s)	0,45 +/-0,05	0,45 +/-0,05	0,45 +/-0,05
Light intensity (lux)	> 1000	> 1000	> 1000
Electrics			
Electrical connection (v)/(Hz)	230 / 50	230 / 50	230 / 50
Power consumption (w)*	59/151	75/198	90/245
Filters			
Pre-filter (ISO 16890)	Coarsefilter	Coarsefilter	Coarsefilter
Horizontal HEPA filter (EN 1822)	H14	H14	H14

*In PowerSave / Workmode

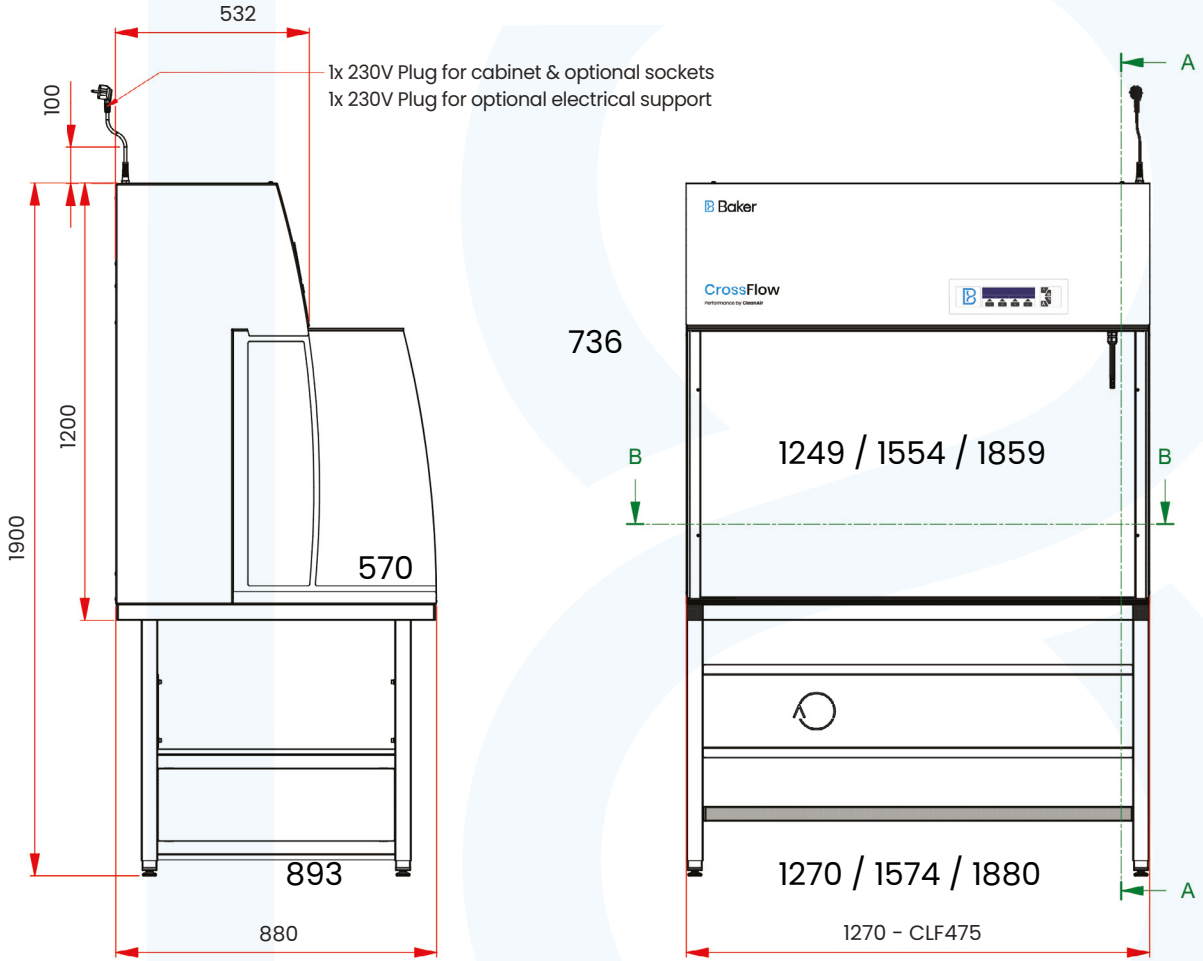

CrossFlow series is a high quality crossflow cabinet range for handling non-hazardous materials that require a clean working environment.

Scan the QR code to learn more about the CrossFlow



 Baker



bakerco.com

